



# SAFE CATALOG 2014

ASSOCIATED LOCK & SUPPLY LTD. IS A DIVISION OF APA

## NOTE TO CUSTOMER

---

Dear Customer,

After 45 years in the business, I have come to acquire a wealth of important knowledge regarding safes. I would like to take this opportunity to pass down some of what I have learned to you; the consumer. The following information is intended to assist you in your decision-making process when purchasing a safe.

First things first, if there's one thing I've learned; it's that **NOT ALL SAFES ARE CREATED EQUAL**. There are some key factors that you **MUST** take into consideration in order to make a properly informed decision that will lead you to the right safe for the job; a safe that is to meet your needs or your customers needs most effectively. By following my few basic tips below, you should find that selecting a safe can be both easier and more accurate to pin point.

Perhaps one of the most important factors you should always consider is size. Be sure to check both the exterior and the interior dimensions of a safe. Remember to **ALWAYS** take into account the thickness of the door which is often overlooked but will affect your inside dimensions when the door is closed.

Quality is usually determined by the weight of a safe. Some manufacturers like to save money by producing a thinner door or body which it turn can make for a much lighter product. Although safes can have like or standard dimensions, you may often find a big difference in the weight of one product to the next depending on the manufacturer. At ALS, we rate our safes for quality using a rating system of 1 to 5 stars that will help you to determine if the safe you are looking to purchase is indeed the quality you are seeking in a product.

Here are some more important factors to keep in mind when selecting a safe:

- What is the fire rating of your safe?  
Is it UL (Underwriter's Laboratories®) certified or is it strictly a manufacturer's rating? Price may vary depending on the certification of the safe. UL certified product is generally more expensive.
- Is the lock on the safe UL approved?
- Can the door of the safe be replaced?  
Should you require the services of a locksmith to access your safe, often it is much easier for the locksmith to replace the door rather than to fill the holes he will drill in order to break into the safe.
- Measure the interior dimensions of any safe you are buying.  
Most manufacturer's don't account for the inside thickness of the door which will subtract space from a safe's inner dimensions.
- Check the safe rating.  
Most safes have a rating or class listed in their product specifications or general information.
- Does the safe have bolt down holes?
- Does the safe have audit trail?  
This is a particularly useful tool for those looking to purchase hotel safes.
- Does the safe have a key override?
- Is your safe powder coated?  
Most of our safes are powder coated. If this is something that's important to you, then be sure to check for this feature.

I encourage you to utilize the above questions as a guideline whenever you are looking to purchase a safe and I hope that I have made your task of selecting a safe a much smoother process.

Yours Sincerely,

FILE PROOF FILE CABINETS	3	HOTEL SAFES	22
DATA MEDIA SAFES	4	FIRST-AID SAFES	24
FIRE RESISTANT SAFES	5	SECURITY CASES	25
BURGLARY SAFES & VAULTS	8	PORTABLE CASH BOXES	26
STEEL MONEY SAFES	14	FLOOR SAFES	27
DEPOSITORY SAFE	15	WALL SAFES	28
UNDER COUNTER SAFES	19	KEY SAFES	30
GUN SAFES	20	KEY CABINETS	39
LAPTOP SAFES	21	CASH BOXES & DRAWERS	42

## FIRE RESISTANT FILING CABINETS

Offer smooth and quiet suspension filing systems to protect your important documents from fire and robbery

### MAIN FEATURES:

- 1 hour fire protection
- Adjustable hanger files accommodate foolscap, A4, letter and legal size documents
- Selective Locking System: Permits locking of any of the 4 drawers either independently or collectively
- Master Drawer Cam on the top drawer controls the lower drawers
- Each drawer is capable of carrying close to 100Kgs of files, way beyond the standard requirement
- Wheels for easy moving (Optional)

### OPTIONAL FEATURES:

- S&G combination lock
- Removable steel wheels
- Wooden compartment for media data storage

### OPTIONAL SET-UPS:

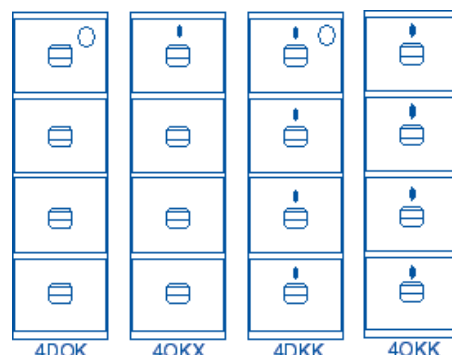

 COMBINATION LOCK

 HIGH SECURITY KEY LOCK



SF-680-4DK



SF-680-3DK



SF-680-2EK

MODEL	O.H"	O.W"	O.D"	I.H"	I.W"	I.D"	LBS.
SF-680-2	33-2/9	20-5/8	26-7/9	11-2/9	15	20-1/2	341
SF-680-3*	47-1/2	20-5/8	26-7/9	11-2/9	15	20-1/2	473
SF-680-4	62	20-5/8	26-7/9	11-2/9	15	20-1/2	605



## DATA MEDIA SAFES

While paper can withstand temperatures of up to 350 °F (177 °C), computer media such as backup tapes, discs, microfilm and microfiche will be damaged beyond use by temperatures above 125 °F (52 °C) and a humidity of above 80%. Our Media & Data Safes also protect your valuables from vandalism and theft as well as possible damage from dust and magnetism.

### FEATURES:

- 2 Hour Fire protection at 125 °F internal temperature
- Internal cabinet protected by an additional fire seal
- Three-way main bolt work with an independent re-locking device
- 2-3/4" solid steel chrome locking bolts & (2) stationary hinge side bolts
- Multi-user electronic lock
- 3-3/8" door & wall thickness
- 1-7/8" inner compartment door & wall thickness
- Wood grain laminate interior finish
- Adjustable shelf in larger models
- Grey/green exterior gloss finish



EDS-100



EDS-020



EDS-080

MODEL	O.H"	O.W"	O.D"	I.H"	I.W"	I.D"	LBS.	SHELF
EDS-020	14	19	15-1/3	4	9-1/4	5-1/2	123	0
EDS-035	24-3/4	19-1/2	18-1/3	11-3/8	8-3/4	6-1/2	242	1
EDS-065	29-3/4	21-7/8	20	16	11	8-1/2	309	2
EDS-080	34-1/2	23-1/5	20	21	12-1/2	8-1/2	375	2
EDS-100	43-1/5	23-1/5	20	28-1/2	12-1/2	8-1/2	507	3

# FIRE RESISTANT HOME & OFFICE SAFES

Fire Resistant home safes are made of a durable gauge steel & not a plastic mould. These units are tested at 1700 °F (927 °C) for 1 Hour with an internal temperature not exceeding 350 °F (177 °C) which is the point that paper contents will start to char. Our hinges are sturdy and have additional hinge side dead-bolts to prevent the door from being jarred off.

**FEATURES:**

- 1 Hour Fire Proof Protection at 1700 °F
- 1-1/2" wall thickness
- 2-1/2" door thickness
- 5/8" solid steel chrome plated locking bolts
- Pre-drilled counter-sunk anchor hole
- Plastic pull out tray for additional storage
- (4) AA Batteries



EM-020

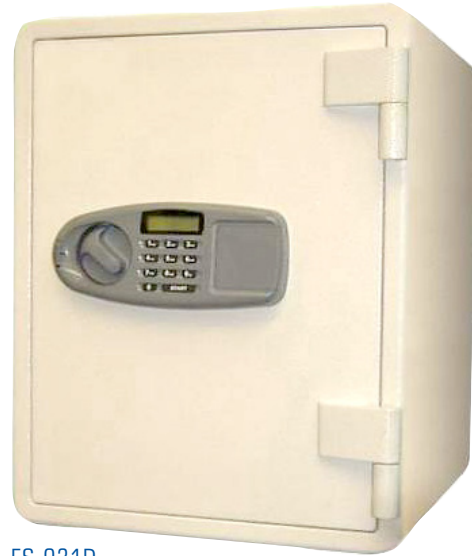

ES-031D

**SM - Dial/Key**  
**EM - Electronic**

MODEL	O.H"	O.W"	O.D"	I.H"	I.W"	I.D"	LBS.	TRAY/SHELF
SM-015/EM-015	11-5/8	15 -3/8	12- 5/8	8 -1/2	12- 3/16	8-1/2	52	1/0
SM-016/EM-016	15 -3/8	11- 5/8	12- 5/8	12- 1/5	8 -1/2	8 -1/2	52	1/0
SM-020/EM-020	14 -3/16	16 -3/4	15- 1/4	9 -5/8	12- 3/4	10 -1/4	79	1/0
SM-030/EM-030	17- 1/3	13 -1/2	15 -1/4	12 -3/4	9 -5/8	10- 1/4	79	1/0

**SS - Dial/Key**  
**ES - Electronic**

MODEL	O.H"	O.W"	O.D"	I.H"	I.W"	I.D"	LBS.	TRAY/SHELF
SS-020/ES-020	14-3/16	18- 7/8	15 -1/4	8- 5/8	14	10 -1/4	100	1/0
SS-030/ES-030	19- 1/2	13 -1/2	15 -1/4	14	8 -5/8	10 -1/4	100	1/0
SS-031/ES-031	21	16- 1/4	15-1/4	17	13	10-7/8	121	1/1
SS-031D/ES-031D	21	16 -1/8	17- 1/2	16 -3/8	12	12 -5/8	132	1/1

## FIRE RESISTANT HOME & OFFICE SAFES

Modern and stylish Fire-resistant safes, perfect for home and/or business use that offer superior fire protection for your valuables and important documents.

### FEATURES:

- Modern and stylish design will fit to anywhere with perfect match
- The button of electronic lock gets activated only when the customer use it, which is more secure
- High security, fire-resistant safes with attractive and compact design
- **1 hour fire protection**
- Two hefty (16-5/8") solid chrome plated locking bolts
- One stationary locking bolt on hinge side to deter prying attack on hinges
- Convenient plastic tray
- Adjustable shelf for model 031D/XD
- Pre-drilled anchor hole (Optional)
- Come in red or black finish



**1 HOUR FIRE PROTECTION**



MODEL	O.H"	O.W"	O.D"	I.H"	I.W"	I.D"	LBS.	TRAY/SHELF
NPS-M020W	13-1/2	16-2/3	15-2/7	9-2/3	12-4/5	10-1/4	92 LBS.	1/0
NPS-020W	13-1/2	18-8/9	15-2/4	8-2/3	14	10-1/4	108 LBS.	1/0
NPS-031DW	20-1/2	16-1/7	17-1/2	16-1/3	12	12-3/5	132 LBS.	1/1



# FIRE RESISTANT HOME & OFFICE SAFES

Ideal for home and / or business use, this fire-resistant safe has enough capacity to hold and protect all of your valuables and important documents from fire. Fire Resistant Office Safes are made using 2 Rust resistant steel plates which form a shell which is then filled with a proprietary fire retardant material. These units are tested at 1700 °F (927 °C) for 2 Hours with an internal temperature not exceeding 350 °F (177 °C) which is the point that paper contents will start to char. Our hinges are sturdy and have additional hinge side dead-bolts to prevent the door from being jarred off. All units come with at least 1 adjustable shelf and an internal key operated upper drawer compartment for additional storage. All units come with an automatic bolt extraction system.

## FEATURES:

- 2 hour fire protection
- High security, fire-resistant safes in a variety of sizes with several certificates
- Detent handle bolt automatically shoots the locking bolts when door closes
- Spring loaded active re-locker system
- Secondary high security dimple key lock on all models
- 3-1/4" door and wall thickness
- 4-3/4" solid steel chrome plated locking bolts
- Lockable drawer + Adjustable shelf
- Wheels for easy moving (Removable wheels are optional.)
- Pre-drilled anchor hole without wheels (Optional)



**2 HOUR FIRE PROTECTION**



SS-035



ES-080



SS-350

**SS - Dial/Key**  
**ES - Electronic**

MODEL	O.H"	O.W"	O.D"	I.H"	I.W"	I.D"	LBS.	TRAY/SHELF
SS-035/ES-035	24-3/4	19 -1/2	18 -1/3	15- 1/3	12-5/8	11-3/4	205	1/1
SS-045/ES-045	28-3/8	19-3/8	18- 3/8	18 -3/4	12 -5/8	11-3/4	220	1/1
SS-065/ES-065	29-3/8	21-7/8	20	20-3/7	15-2/3	13-1/4	287	1/1
SS-080/ES-080	34-1/2	23-1/4	20	24-3/4	16 -3/8	13- 1/4	353	1/1
SS-100/ES-100	43-3/16	23-1/4	20	32 -5/8	16 -3/8	13 -1/4	463	1/2
SS-150/ES-150	49-1/2	25 -1/2	25	39 -3/4	18-5/16	18	624	1/2
SS-200/ES-200	53 -7/8	29-1/4	25	44	22	18	705	1/2
SS-350/ES-350	66	29-5/16	25	56	22	18	859	1/3
SS-400/ES-400	66	33	25	56	26	18	1058	1/3
SS-700/ES-700	70	47 -1/2	27	59-7/8	40-1/2	20	1433	2/3

# COMPOSITE FIRE & BURGLARY SAFES

## IGNUM

41010/41050/41060

EAN: 8425181 \* \*



### TECHNICAL SPECIFICATION

Thickness: 41010: 59mm solid steel and vibrated concrete casing, 37mm door. 41050 and 41060: 65mm solid steel and vibrated concrete casing, 42mm door.

Bolts / diameter: 41010: 1 bolt, 30mm long x 15mm wide. 41050 and 41060: 4/ ø25 mm

Interior anti-lever locks.

Thermally insulated casing and door.

Digital display: User-friendly help messages displayed on screen.

Colour: Embossed grey.

Anchoring: Fixing holes in the base. Special fittings included.

Shelf: 1 (except ref. 41010).

Contains an interior coffer with key (except ref. 41010).

### OPENING

Opening mechanism 41010: Electronic with knob. 41050 y 41060: Electronic with lever. To close safe, on pushing the door, the bolts lock the door automatically.

Access code: User free to choose and set 2 access code between 4 and 8 digits

Entry audit of the last 14 openings.

Emergency opening: Tubular emergency key.

Back-up power supply: External connector included, 4 1.5V batteries, in case batteries run out.

Alarm system: Activates with in correct access code or attempted forced entry.

Setting: Setting button located inside.

### EXTRAS

- Shock resistant and fire resistant.
- Complies with US regulation UL72, CLASS 350 fire resistance of documents for 1 hour.
- Interior capable of withstanding temperatures close to 120°C while exterior resistance can reach temperatures of 1030°C over 1 hour.
- Impact resistance test approved for impacts over 9 m in height (except ref. 41010).
- Ref. 41060 meets minimum standards set down by insurers (+100kg).



41050

Ref.	measurements (mm)	↔	↑↓	↙↘	Kg	📦	* EAN	
41010	exterior	420	300	360	28	12	410103	
	interior	300	180	225				
41050	exterior	480	600	480	82	47	410509	
	interior	343	463	300				
41060	exterior	500	700	480	101	61	410608	
	interior	363	563	300				



Four 25mm rotary locking bolts and 2 internal anti-lever bolts fixed to safe doors 41050 y 41060.



Tubular emergency key in case secret code is misplaced.



41010 knob-opening mechanism.

## COMPOSITE FIRE & BURGLARY SAFES

Offers smooth and quiet suspension filing system to protect your important documents from fire and robbery. The SB Series of Safe offers you 2 Hours of Fire Protection along with Superior Burglary Protection. These units are capable of protecting your valuables against a full out burglary attack. The door and body are beefed up with oversized hinges; we have added an additional glass re-locker along with our standard hard-plate to protect the locking device. These units allow you to leave your valuables knowing they are in good hands.

### FEATURES:

- Heavy Duty 2 hour fire protection and premium security
- Full composite steel and concrete construction
- 2" thick walls, with a 5" thick door
- UL Group II combination lock
- Hard plate protects locking mechanism and bolt cam
- Remote glass re-locker to prevent drill attacks
- 1 1/4" massive chrome plated solid steel bolts
- Massive heavy duty Ball bearing hinges
- Adjustable shelving
- Tri-spoke handle
- 1 recessed bolt-down hole to anchor to the ground



**2 HOUR FIRE PROTECTION**



SB-02



SB-03



SB-06

MODEL	O.H"	O.W"	O.D"	I.H"	I.W"	I.D"	LBS.	SHELF
SB-01	17 -3/4	17 -3/4	20 -1/2	12	12	12 -1/2	165	1
SB-02	27	20	20 - 1/2	21- 1/4	14	12- 1/2	311	2
SB-03	33 -1/4	20	22- 3/4	27	14	15	434	2
SB-04	33 -1/4	28	29	27	22 -1/4	21	622	2
SB-05	41- 1/2	28	29	35- 5/16	22- 1/4	21	789	2
SB-06	59 -1/4	28	29	53	22 -1/4	21	955	3

## COMPOSITE FIRE & BURGLARY SAFES

The RS Series of Safe offers you both Fire and Burglary protection with enormously increased storage capacity. These units are tested at 1700 °F (927 °C) for 1-1/2 Hours with an internal temperature not exceeding 350 °F (177 °C) which is the point that paper contents will start to char. This safe provides an affordable way to secure important documents and valuables without compromising security. Every home and business should have one. If you value your important documents, jewelery or cash then protect it from both fire and theft.

### FEATURES:

- 2 1/2" thick door which includes 1/2" solid high tensile steel
- Combination Lock
- Three 3/4" Solid Steel Chrome plated locking bolts
- Hard plate protects locking mechanism and bolt cam
- Spring loaded tempered glass re-locker
- Deadbolts on hinge side of door for additional security
- Adjustable shelving
- Recessed bolt-down hole to secure to the ground
- Stainless Steel Facia plate to prevent scratches
- High Quality Beige paint finish



RS-1



RS-2

MODEL	O.H"	O.W"	O.D"	I.H"	I.W"	I.D"	LBS.	SHELF
RS-0	17-1/4"	15"	16-3/4"	13"	10-1/4"	12-1/4"	150 LBS.	1
RS-1	20"	17-3/4"	17-3/4"	15-1/4"	13"	12-1/4"	175 LBS.	2
RS-2	25-3/4"	21-1/4"	20"	21-1/2"	16-1/2"	15-1/2"	225 LBS.	2
RS-3	31-3/4"	21-1/4"	20"	27-1/2"	16-1/2"	15-1/2"	300 LBS.	2
RS-4	31-3/4"	28-1/4"	28-1/4"	27-1/2"	23-1/2"	23-1/2"	450 LBS.	2
RS-5	39-3/4"	28-1/4"	28-1/4"	35-1/2"	23-1/2"	23-1/2"	600 LBS.	3

## COMPOSITE FIRE & BURGLARY SAFES

The CLSB Series of safes offers you everything you need in Security against Theft and Fire. This unit is identical to the SB Series however in addition to it's high security features it also uses a high PSI (pounds per square inch) composite and aggregate mixture. These units can be classified as "CLASS 2" security vaults, or TL15 equivalents.

### FEATURES:

- 2 hour fire protection and premium security
- Full composite steel with a high PSI concrete & aggregate construction
- 2" thick walls, with a 5" thick door • Combination lock
- Hard plate protects locking mechanism and bolt cam
- Remote glass re-locker to prevent drill attacks
- 1-1/4" massive chrome plated solid steel bolts
- 1-1/4" massive chrome plated stationary bolts
- Massive heavy duty Ball bearing hinges adjustable shelving
- Tri-spoke handle
- 1 recessed bolt-down hole to anchor to the ground
- Grey/Green paint finish



**2 HOUR FIRE PROTECTION**



MODEL	O.H"	O.W"	O.D"	I.H"	I.W"	I.D"	LBS.	SHELF
CL-SB01	17-3/4"	17-3/4"	20-1/2"	11-3/8"	11-3/8"	12-1/2"	410 LBS.	1
CL-SB02	27"	20"	20-1/2"	20-1/2"	13-3/4"	12-1/2"	615 LBS.	2
CL-SB03	33-1/4"	20"	22-3/4"	27"	13-3/4"	14-7/8"	780 LBS.	2
CL-SB04	33-1/4"	28"	29-1/4"	27"	21-5/8"	21"	1000 LBS.	2
CL-SB05	41-1/2"	28"	29-1/4"	35"	21-5/8"	21"	1375 LBS.	2

## BURGLARY FIRE SAFES

### FEATURES:

- "C" Rated Burglary Safe
- Door is 1" plate steel construction
- Body is 1/2" plate steel construction
- Specially reinforced door frame
- Independent re-locking mechanism
- Chrome plated locking bolts
- Bottom (inside) cover plate with felt surface



**1 HOUR FIRE PROTECTION**



AV1212-11

MODEL	O.H"	O.W"	O.D"	LBS.
AV1212-11	12-1/2"	12"	11"	185 LBS.
AV1814-14	18-1/2"	14"	14"	LBS.
AV1818-16	18-1/2"	18"	16"	365 LBS.
AV2416-14	24-1/2"	16"	14"	LBS.
AV2618-16	26-1/2"	18"	16"	475 LBS.
AV4018-16	40-1/2"	18"	16"	670 LBS.

## BURGLARY FIRE SAFES

### FEATURES:

- Class 2
- Built to TL-15 specs
- Finally a heavy duty safe



MODEL	O.H"	O.W"	O.D"	I.H"	I.W"	I.D"	LBS.	SHELF
AP1C-TC	31-3/5"	18-1/5"	20-1/2"	14-1/7"	12-1/2"	12-4/5"	612 LBS.	1
AP2C-TC	36-3/5"	18-1/5"	20-1/2"	19"	12-1/2"	12-4/5"	667 LBS.	1
AP3C-TC	42-3/5"	18-1/5"	20-1/2"	25"	12-1/2"	12-4/5"	755 LBS.	1

# HEAVY DUTY BURGLARY SAFES

For use in the home or office, the Mutual Gem Vault with its six-sided composite construction and **2 hour fire protection** is the only choice. Available in TL15.

## GEM VAULT BY MUTUAL

### FEATURES:

- Massive 2" thick door, 5 1/4" overall
- Active 1 1/4" chromed locking bolts
- Tempered glass re-locker
- Chrome-plated die cast handle
- Adjustable shelves
- Stainless fascia plates



**2 HOUR FIRE PROTECTION**

### CONSTRUCTION

All around the world, the Mutual Gem Vault sets the standard in TL-15 protection. The Gem Vault's body consists of 9,000 PSI concrete embodied with corundum aggregate and encased in a double layer of high-tensile steel. The door is nearly 5 1/4" in overall thickness which includes 2" of solid barrier material.

### PROTECTION

Massive 1 1/4" chromed locking bolts, secured with a high-security combination lock are standrd on the Gem Vault. The lock is mounted on a magnesium anit-drilling and cutting plate, and as an extra measure, a plate of tempered glass connected to a randomly placed relocker, is mounted behind the combination lock



GV-2512



GV-2520



GV-4520

	OUTSIDE			INSIDE			WEIGHT	SHELF	CU.FT.
	H	W	D	IH	IW	ID			
GV-1412	20"	18-1/2"	20-1/2"	14"	12-1/2"	12"	480 LBS.	1	1.2
GV-1912	25"	20-1/2"	20-1/2"	19"	18-1/2"	18"	560 LBS.	1	1.6
GV-1918	25"	24-1/2"	27-1/2"	19"	18-1/2"	18"	850 LBS.	1	3.6
GV-2512	31"	18-1/2"	20-1/2"	25"	12-1/2"	12"	650 LBS.	1	2.2
GV-2520	31"	26"	29"	25"	20-1/2"	21"	1000 LBS.	2	6.2
GV-3020	36"	26.5"	29"	30"	20-1/2"	21"	1150 LBS.	2	7.3
GV-4520	51"	26-1/2"	29"	45"	20-1/2"	21"	1600 LBS.	3	11.2
GV-5920	65"	26-1/2"	29"	59"	20-1/2"	21"	1750 LBS.	3	14.7

# HEAVY DUTY BURGLARY SAFES

Six-sided composite construction and 2 hour fire protection places the Mutual Jewel Vault in a class of it's own.

## FEATURES:

- Six-sided composite construction + **2 hour fire protection**
- A massive 7" thick door, 3" of barrier material
- Huge tempered glass protection with dual adjustable re-locker
- 7 x 2" chromed locking bolts
- Tri-spoke die cast handle with satin chrome finish
- Adjustable shelves
- Stainless Steel fascia plate
- Adjustable hinges with hardened bearings
- 3-way boltwork
- Dual Glass Relocker

## PROTECTION

The Jewel Vault incorporates up to seven massive 2" chromed locking bolts, secured with two high-security combination locks. A huge floating glass plate "nerve center" covers the entire locking area. Additionally, the mechanism is protected by dual plates of tempered glass which will activate two randomly located relocking devices in the event of a burglary attack. For ease of use the tri-spoke relocker is adjustable and equipped with an internal captive cross lock which secures the relocker bolt once it has fired.

## CONSTRUCTION

For those seeking the ultimate in TL-30 security, the Mutual Jewelry Vault provides the answer. The Jewel Vault's composite body is a solid 3" thick and incorporates 18,000 PSI density concrete embodied with corundum aggregate and encased in a double layer of high-tensile steel. The door is 6 1/2" in overall thickness which includes 3" of solid barrier material.



**2 HOUR FIRE PROTECTION**



JV-5524

JV-5534

JV-6034

	OUTSIDE			INSIDE			WEIGHT	SHELF	CU.FT.
	H	W	D	IH	IW	ID			
JV-3020/DV-3020	38"	28"	29-1/2"	30"	20"	18"	1900 LBS.	2	7.3
JV-4524/DV-4524	53"	32"	32-1/2"	45"	24"	21"	2800 LBS.	3	13.1
JV-5524/DV-5524	63"	32"	32-1/2"	55"	24"	21"	3250 LBS.	4	16
JV-5534/DV-5534	63"	42"	32-1/2"	55"	34"	21"	3600 LBS.	4	22.7
JV-6034/DV-6034	68"	42"	32-1/2"	60"	34"	21"	3950 LBS.	5	24.8
JV-6528/DV-6528	73"	36"	32-1/2"	65"	28"	21"	3800 LBS.	5	22.1
JV-6836/DV-6836	76"	44"	37-1/2"	68"	36"	26"	5000 LBS.	5	37

## STEEL MONEY SAFES

The Solid Steel Money Chest is an alternative to the more expensive Fire/Burglary Vaults, if money is an issue and you don't feel you require Fire protection then this is the perfect solution. Secure your cash and valuables where a thief can't easily access them such as under your cash tray in the register.

**FEATURES:**

- "B" Rated Solid Plate Steel Safe
- 1/2" door & 1/4" body
- Combination lock on "C" models
- Programmable electronic lock on "E" models
- Independent spring loaded re-locking mechanism
- 5 active 32 mm diameter chromed locking bolts
- 4 bolt holes for anchoring to the ground
- Grey/Green color finish



S838C



S852E



S874E

	H	OUTSIDE			INSIDE		ID	WEIGHT	SHELF
		W	D	IH	IW				
S838C/E	15"	15-3/4"	12-5/8"	14-1/2"	15-3/4"	10-1/2"	128 LBS.	1	
S852C/E	20-1/2"	15-3/4"	18-1/8"	20"	15-1/4"	15-4/5"	161 LBS.	2	
852C/E	21-1/4"	19-1/4"	22-13/16"	20-3/4"	18-3/4"	20-1/2"	206 LBS.	2	
874C/E	29-1/8"	19-1/4"	22-13/16"	28-3/4"	18-3/4"	20-1/2"	271 LBS.	2	

C = COMBINATION • E = ELECTRONIC

## STEEL MONEY SAFES

- "B" Rated solid plate 1/2" door & 1/4" body
- Combination or electronic lock
- 5 active 32mm diameter chromed bolts
- 4 anchor bolt holes on bottom
- Programmable from 3 - 8 digit lock with key override
- Moulded round corners
- T-handle



B1515E



B2018E

	OUTSIDE			INSIDE		ID	WEIGHT	SHELF
	H	W	D	IH	IW			
B1515C/E	15"	15"	15"	14-1/2"	15-1/4"	10-1/2"	128 LBS.	1
B2018C/E	20"	18"	15"	20"	15-1/4"	15-4/5"	161 LBS.	1

C = COMBINATION • E = ELECTRONIC



# DEPOSITORY SAFES

The ideal safe when immediate deposits and secure storage of cash or other valuables are needed.

**FEATURES:**

- Class B-Rated insurance rating with 1/2" thick high strength steel doors
- Combination lock
- 12mm (1/2") thick door, 6mm (1/4") thick body
- Front loading designed to fit most large money bags & envelopes
- High strength steel body
- Rough steel plate door & body
- Top loading design, (rotary hopper models) will fit most large

- money bags
- Can be equipped with a electronic digital lock, combination lock, dual key lock, etc.
- Boltwork features three strong steel locking bolts
- Handle designed to break away in a forced entry attack
- Solid steel dead bar to prevent removal of door if hinges are removed
- 4 anchor bolt holes standard - Hopper & slot are protcted by "ANTI-FISH" baffles

**FL2813-C (COMBO LOCK)**

**FL2813-E (ELECTRONIC LOCK)**

- "B" Rated Front Load Depository
- 12mm thick door, 6mm thick body
- Front loading designed to fit most large money bags and envelopes
- T-handle
- Moulded round corners
- Outside: H27-1/2" X W13-1/2" X D15"
- Inside: H18" X W13" X D14-1/2"
- Front Loading: H7-3/4" X W14-3/4"
- Weight: 152 lbs.



**FL3020C (COMBO LOCK)**

- "B" Rated Front Load Depository
- 12mm thick door, 6mm thick body
- Front loading designed to fit most large money bags and envelopes
- T-handle
- Moulded round corners
- Combination lock
- Outside: 30"H X 20"W X 20"D
- Weight: 203 lbs.



**FL3216-EE (ELECTRONIC)**

- Front Load Depository "B" Rated
- Outside: H32-3/4" X W15-3/4" X D15-3/4"
- Inside: H10-3/4" X W13" X D13"
- Front Loading: H7-3/4" X W14-3/4"
- Weight: 210lb.



**FL3914-CC (COMBO LOCK)**

**FL3914-EE (ELECTRONIC LOCK)**

- "B" Rated Front Load Depository
- 12mm thick door, 6mm thick body
- Front loading designed to fit most large money bags and envelopes
- T-handle
- Moulded round corners
- Outside: H39" X W13-1/2" X D15"
- Inside: H29-1/2" X W13" X D14-1/2"
- Front Loading: H7-3/4" X W14-3/4"
- Weight: 216 lbs.



**RL2818C**

- New "Rear" Depository Safe
- Outside: 28"H x 18"W x 20"D
- Opening: 17"H x 15"W x 18"D
- Rear deposit slot: 14"W x 4"H



# DEPOSITORY SAFES

The ideal safe when immediate deposits and secure storage of cash or other valuables are needed.

## FEATURES:

- **Class B-Rated insurance rating with 1/2" thick high strength steel doors**
- Combination lock
- 12mm (1/2") thick door, 6mm (1/4") thick body
- Front loading designed to fit most large money bags & envelopes
- High strength steel body
- Rough steel plate door & body
- Top loading design, (rotary hopper models) will fit most large money bags
- Can be equipped with a electronic digital lock, combination lock, dual key lock, etc.
- Boltwork features three strong steel locking bolts
- Handle designed to break away in a forced entry attack
- Solid steel dead bar to prevent removal of door if hinges are removed
- 4 anchor bolt holes standard - Hopper & slot are protected by "ANTI-FISH" baffles

### RH2014-C (COMBO LOCK)

### RH2014-E (ELECTRONIC LOCK)

- Rotary Hopper Safe
- Dual nose key lock
- UL-Listed combination lock
- Outside: 20"H x 13-1/2"W x 15-1/2"D
- Weight: 140 lbs.



### RHS2410-C (COMBO LOCK)

- Rotary Hopper Safe
- Dual nose key lock
- Outside: 20"H x 10-1/4"W x 14"D
- Weight: 139 lbs.



### RK-01 (KEY)

### RC-01 (COMBINATION)

- "B"-rated burglary construction (1/2" solid steel door and 1/4" solid steel body). Deposits protected with anti-fish baffles.
- Outside: 24-1/2"H x 10-1/2"W x 14-1/2"D
- Inside: 16-2/3"H x 10-1/6"W x 12-1/5"D
- Top Loading: 5"H x 9-3/4"W
- Weight: 136 lbs.



### RC-02 (COMBINATION)

- "B"-rated burglary construction (1/2" solid steel door and 1/4" solid steel body). Deposits protected with anti-fish baffles.
- Outside: 35-1/4"H x 13-1/4"W x 14-1/2"D
- Inside: 13-1/5"H x 12-4/5"W x 12-1/5"D
- Top Loading: 5"H x 9-3/4"W
- Weight: 235 lbs.



### SC-02 (COMBINATION)

- Outside: 28"H x 13-1/4"W x 14-1/2"D
- Inside: 12-2/3"H x 12-4/5"W x 12-1/5"D
- Top Loading: 1/2"H x 9-3/4"W
- Weight: 176 lbs.



### FL1913-E (ELECTRONIC LOCK)

### FRONT LOAD DEPOSITORY

- "B" rated
- Outside: H19" X W13-1/2" X D15"
- Inside: H12-2/3" X W13" X D14-1/2"
- Front Loading: H7-3/4" X W14-3/4"
- Weight: 114lb.



# DEPOSITORY SAFES

The ideal safe when immediate deposits and secure storage of cash or other valuables are needed.

## FEATURES:

- Class B-Rated insurance rating with 1/2" thick high strength steel doors
- Combination lock
- 12mm (1/2") thick door, 6mm (1/4") thick body
- Front loading designed to fit most large money bags & envelopes
- High strength steel body
- Rough steel plate door & body
- Top loading design, (rotary hopper models) will fit most large money bags
- Can be equipped with a electronic digital lock, combination lock, dual key lock, etc.
- Boltwork features three strong steel locking bolts
- Handle designed to break away in a forced entry attack
- Solid steel dead bar to prevent removal of door if hinges are removed
- 4 anchor bolt holes standard - Hopper & slot are protected by "ANTI-FISH" baffles

### ER-01 (ELECTRONIC LOCK)

- Outside: 24-1/2"H X 10-5/8"W X 14-1/2"D
- Inside Top & Bottom: 16-2/3"H X 10-1/6"W X 12-1/5"D
- Top Loading: 5"H x 9-3/4"W
- Weight: 130 lbs.



### ER-02 (ELECTRONIC LOCK)

- Outside: 35-1/4"H X 13-1/4"W X 14-1/2"D
- Inside Top & Bottom: 13-1/5"H X 12-4/5"W X 12-1/5"D
- Top Loading: 5"H x 9-3/4"W
- Weight: 238 lbs.



### ES-02 (ELECTRONIC LOCK)

- Outside: 28"H X 13-1/4"W X 14-1/2"D
- Inside Top & Bottom: 12-2/3"H X 12-4/5"W X 12-1/5"D
- Top Loading: 1/2"H x 9-3/4"W
- Weight: 176 lbs.



### S747K (KEY)

### S747C (COMBINATION)

### S747E (ELECTRONIC)

- Outside: 18-1/2"H X 15"W X 10-1/5"D
- Inside Top & Bottom: 12-1/5"H X 14-1/2"W X 8"D
- Top Loading: 7-3/4"H x 13"W
- Weight: 88 lbs.



### S752C (COMBINATION)

### S752E (ELECTRONIC)

- Outside: 20-1/2"H X 15-3/4"W X 15-3/4"D
- Inside Top & Bottom: 12-1/5"H X 13-1/2"W X 13-1/2"D
- Top Loading: 7-3/4"H x 13"W
- Weight: 150 lbs.



### RH1309-C (COMBO LOCK)

### RH1309-K (KEY LOCK)

### ROTARY HOPPER SAFE

- Dual nose key lock
- Combination lock
- Outside: 13"H x 8-1/4"W x 11-3/4"D
- Weight: 64 lbs.



# DEPOSITORY SAFES

The ideal safe when immediate deposits and secure storage of cash or other valuables are needed.

## FEATURES:

- **Class B-Rated insurance rating with 1/2" thick high strength steel doors**
- Combination lock
- 12mm (1/2") thick door, 6mm (1/4") thick body
- Front loading designed to fit most large money bags & envelopes
- High strength steel body
- Rough steel plate door & body
- Top loading design, (rotary hopper models) will fit most large money bags
- Can be equipped with a electronic digital lock, combination lock, dual key lock, etc.
- Boltwork features three strong steel locking bolts
- Handle designed to break away in a forced entry attack
- Solid steel dead bar to prevent removal of door if hinges are removed
- 4 anchor bolt holes standard - Hopper & slot are protected by "ANTI-FISH" baffles

### SDS-01C (COMBINATION) SDS-01E (ELECTRONIC)

- Outside:  
18-8/9"H x 13-2/5"W x 15"D
- Inside: 9-5/7"H x 13"W x 12"D
- Top Loading: 4-5/7"H x 11"W
- Door: 1
- Bolts: 5
- Weight: 112 lbs.



### SDS-02C (COMBINATION) SDS-02E (ELECTRONIC)

- Outside: 27-1/2"H x 13-2/5"W x 17"D
- Inside: 19-7/8"H x 13"W x 14"D
- Top Loading: 4-5/7"H x 11"W
- Door: 1
- Bolts: 5
- Weight: 150 lbs.



### SDS-03CC (COMBINATION) SDS-03EE (ELECTRONIC)

- Outside:  
39"H x 20-2/7"W x 22"D
- Inside:  
31-3/8"H x 19-4/5"W x 12"D
- Top Loading: 4-5/7"H x 13"W
- Door: 2
- Bolts: 5
- Weight: 334 lbs.



### S3D-3020

- Outside: 30"H x 20"W x 16"D
- Inside Top & Bottom:  
9-3/4"H x 19-1/2"W x 13-3/4"D
- Top Loading: 3-7/8"H x 3-7/8"W
- Weight: 220 lbs.



### S1C-3020

- Outside: 30"H x 20"W x 20"D
- Inside Top & Bottom:  
22"H x 19-1/2"W x 17"D
- Top Loading: 9"H x 19-1/2"W
- Weight: 231 lbs.

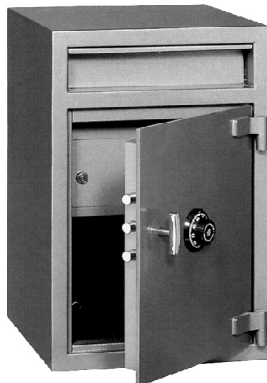

### S782CC (COMBINATION LOCK) S782EE (ELECTRONIC LOCK)

- Front Load Depository
- "B" Rated
- Outside:  
H20-1/2" X W15-3/4" X D15-3/4"
- Inside:  
H12-1/5" X W15-3/4" X D12-1/2"
- Front Loading: H7-3/4" X W13"
- Weight: 150 lbs.



## UNDER COUNTER SAFES

### COMMERCIAL CASH HANDLING SAFES

- Your best in anti-holdup and pilferage protection
- Deposit slot with anti-fish baffle
- Solid steel plate door & body
- Combination lock or key lock
- 4 bolt down holes in bottom



UCS8612-C



UCS12810-K

	OUTSIDE			SLOT		WEIGHT
	H	W	D	IH	IW	
UCS8612-C/UCS8612-K	8"	6"	12"	1/2"	5"	34 LBS.
UCS12810-C/UCS12810-K	12"	8"	10"	1/2"	7"	47 LBS.

K = KEY • C = COMBINATION

## SMALL DEPOSIT SAFE

### ST-12D

- External size: 11.8"W x 14"D x 5"H
- Weight: 18 lbs.
- Body Thickness: 3mm
- Door Thickness: 5mm



# GUN SAFES

## FEATURES:

- Fire activated expendable door seal for fire proof gun safes Lock
- LaGard Group II Lock with VisionGuard + brass plated spyproof ring and dial
- 7 1-1/2" diameter moving locking bolts
- 1-3/4" composite door and body
- Pre-drilled for anchoring to floor - anchoring hardware included
- Comes in 3 exterior colours: powder coated semi-gloss black, green or burgundy
- Interior colour of light gray
- Upholstered adjustable interior
- Hardplate (HRC 60 hardness)
- 7 active bolts (5+1+1), dia. 38mm
- Steel thickness: 1/8" body • 1/4" door
- 3 deadbolts

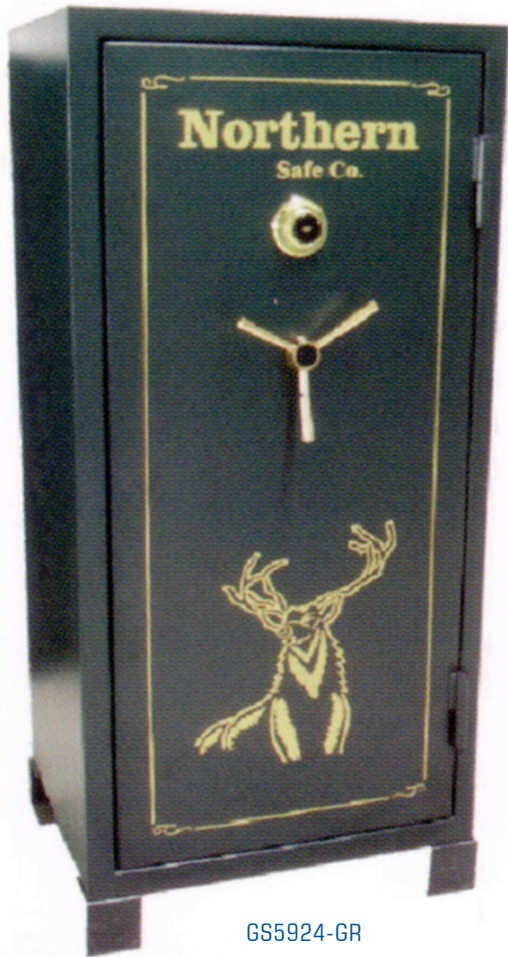

GS5924-GR



GS5930-GR

	OUTSIDE			WEIGHT	GUNS & RIFLES	
	H	W	D			
GS5924	59"	24"	22"	520 LBS.	20	- BRASS PLATED DROP STYLE HANDLE
GS5930	59"	30"	24"	615 LBS.	22	- BRASS PLATED TRI-SPOKE HANDLE
GS5939	59"	39"	24"	745 LBS.	39	- BRASS PLATED TRI-SPOKE HANDLE
GS7242	72"	42"	27.5"	959 LBS.	39	- BRASS PLATED TRI-SPOKE HANDLE

# ELECTRONIC LAPTOP SAFES

## ELECTRONIC CLASS

T-20EB/T-25EB/T-35EB

EAN: 8425181 \* \*



### TECHNICAL SPECIFICATION

Thickness: 4mm steel front and 2mm casing.

Bolts / diameter: 2 / ø18 mm.

Colour: Dark grey.

Anchoring: Fixing holes in the base and back.



T-20EB

### OPENING

Opening mechanism: Electronic knob-operated.

Access code: User free to choose and set access code between 4 and 2 digits.

Emergency opening: Tubular emergency key.

Setting: Setting button located inside.

### EXTRAS

→ Laptops easily stored in Ref. T35EB

Ref.	measurements (mm)	↔	↕	↙	Kg	⊠	* EAN	
T-20EB	exterior	310	200	200	7	9	220887	
	interior	300	190	150				
T-25EB	exterior	350	250	250	10	17	225882	
	interior	340	240	200				
T-35EB	exterior	430	200	350	12	24	235881	
	interior	420	190	300				



Double-bolting lock at 2 different heights ensure door completely secure in locked position.



Fixing holes in the base and back.



Laptops easily stored in Ref. T35EB



## PRACTIC HOTEL

51010 / 51030

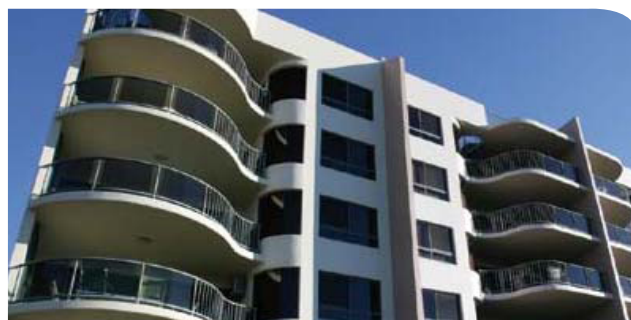

REF.51030  
SUITABLE  
FOR LAPTOPS.



Ref. 51030

### PHYSICAL FEATURES:

No. of bolts:  
2 bolts.

Fitting:  
With fitting holes at the base and back. Screws are included.

Finish:  
Dark grey.

### OPENING FEATURES:

Opening system:  
Electronic with handle.

Damp-proof circuit.

Code:  
It has 2 access codes (user and master). Codes may be personalised, from 4 to 8 digits.

Emergency key:  
It has an emergency master key.

Batteries:  
With batteries for first-time use.

### OPTIONS:

Rental key.

External power supply.  
especial finishes available.

REFERENCE	51010	51030
External Measurement:		
Height	250	200
Width	350	430
Depth	250	350
Internal Measurement:		
Height	240	190
Width	340	420
Depth	200	300
Weight(kg):	10	12
VOLUME (L):	17	24
*EAN 13: 8425181	510100	510308

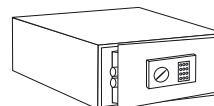
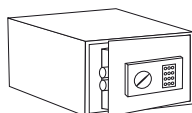





# BUSINESS HOTEL

51130



SUITABLE FOR LAPTOPS



Ref. 51130

**PHYSICAL FEATURES:**

Thickness: 2 mm body and 6 mm door.  
 No. of bolts: 2 bolts.  
 Fitting:  
 With fitting holes at the base and back. Screws are included.  
 Finish: Graphite.

**OPENING FEATURES:**

Opening system:  
 Electronic motorised.  
 Damp-proof circuit.  
 Code:  
 Opening code from 4 to 6 digits. Master code may be personalised.  
 Emergency key:  
 It has an emergency master key.  
 Batteries:  
 With batteries for first-time use.  
 Display:  
 It has a digital display.

**OPTIONS:**

Interior multi-zone plug socket for electronic appliances.  
 Interior light.  
 Special finishes available.  
 Optional left-hand opening.

REFERENCE	51130
External Measurement:	
Height	200
Width	445
Depth	380
Internal Measurement:	
Height	190
Width	440
Depth	300
Weight(kg):	14,7
VOLUME (L):	21
*EAN 13: 8425181	511305

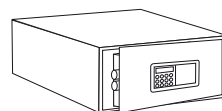

# FIRST-AID CABINET

## MEDICAL CABINETS

BT-001/BT-011/BT-002

EAN: 8425181 \* \*

### TECHNICAL SPECIFICATION

Material: Painted Steel casing and door. Model BT-002 available with glass door.

Use: Conveniently placed shelves allow for easy storage of medical and first aid material, optimizing use of space.

Medical and first aid materials not supplied.

Colour: Light grey.



BT-001

### OPENING

Standard cut key lock.

Ref.	measurements (mm)	↔	↕	↙	* EAN	
BT-001	exterior	315	360	100	200018	
BT-011	exterior	360	450	150	200117	
BT-002	exterior	315	360	100	200025	



BT-001.



BT-011.



BT-002.

## SECURITY CASES

Fire resistant safe box protects paper to 1550°F during a fire for 30 minutes. Includes a key lock.



2011



2017



2037

MODEL	O.H"	O.W"	O.D"	CU.FT.	LBS.
2011	5-5/8	13-7/8	10-3/4	16	16.5
2017	5-3/4	16-1/3	12-3/4	18	19
2037	12-13/16	15-3/4	12-1/2	62	41.8

## SECURITY CASES

### BRIG

C-9547

EAN: 8425181 \*

### TECHNICAL SPECIFICATION

Material: Painted Steel.

Use: Portable Safety Deposit box with handle.

Convenience: Cushioned interior to protect contents.

Colour: Textured black.



C-9547

Ref.	measurements (mm)	↔	↕	↙	Kg	Q1	* EAN
C-9547	exterior	325	130	255	5	-	195475

### OPENING

Opening mechanism: Electronic knob-operated.

Access code: User free to choose and set access code between 1 and 8 digits.

Emergency lock: Includes emergency key in case password is misplaced or batteries run out.



Ref. C-9547: Electronic knob-opening mechanism and emergency lock.



Ref. C-9547: Portable Safety Deposit box.

# PORTABLE CASH BOXES

## PRIVATE

C-9327/C-9427/C-9467

EAN: 8425181 **\***

### TECHNICAL SPECIFICATION

Material: Painted Steel.

Use: Secure fix cash box.

Convenience: Cushioned interior to protect contents.

Colour: Black.



C-9327

### OPENING

Opening mechanism: Ref. C-9327 and C-9467 key lock. Ref. C-9427 combination lock.

### EXTRAS

- C-9427 Y C-9467: supplied with 1 metre steel cable for fastening safety deposit box to fixed point, rendering it unmovable.
- C-9327: supplied with easily-attachable steel base, fixing safety deposit box to base, locking with key and rendering it unmovable.

Ref.	measurements (mm)	↔	↕	↗	kg	📦	* EAN	
C-9327	exterior	160	75	203	1,3	-	193273	
C-9427	exterior	150	65	203	0,8	-	194270	
C-9467	exterior	150	95	203	0,9	-	194676	



Ref. C-9327: Includes steel base allowing safe to be fixed in place.



# FLOOR SAFES

These solid steel Floor Safes are an ideal way of ensuring your valuables are safe. The floor safe has an advantage over you standard above ground safe in that it is concealed from the naked eye. A would be burglar wants to get in and out quickly so the chances of them lifting up every carpet or rug in your home/business is unlikely.

**FEATURES:**

- B-Rated Solid Steel Construction (1/2" steel door & 1/4" steel body)
- Armed with Drill resistant hard plate construction
- Combination lock
- All sides seamlessly welded
- Heavy duty hinges (Coil Spring allows for easy opening and closing)
- 3-3/4" chrome plated solid steel locking bolts with an independent re-locking device
- Full length locking bar to deter prying attack on hinges
- Steel Dust Cover included for flush floor finish and concealment
- Rust resistant exterior gloss finish
- EF Models = electronic • FS Models = combination



**FS-B1**  
 Outside: H14" X W14" X D12-1/2"  
 Inside: H13-1/2" X W13-1/2" X D7-1/4"  
 Weight: 101 lbs.



**FS-B2**  
 Outside: H14" X W14" X D16-1/8"  
 Inside: H13-1/2" X W13-1/2" X D11-1/3"  
 Weight: 137 lbs.



**FS-B3**  
 Outside: H14" X W14" X D20-5/16"  
 Inside: H13-1/2" X W13-1/2" X D15-1/2"  
 Weight: 154 lbs.



**FS-B4**  
 Outside: H18" X W24" X D18"  
 Inside: H13-1/2" X W23-1/2" X D13-1/2"  
 Weight: 158 lbs. • Boot Shape

**FS-C1**  
 Outside: H14" X W14" X D12-1/2"  
 Inside: H13-1/2" X W13-1/2" X D7-1/4"  
 Weight: 101 lbs. • 1" Door

**IFS-0813**  
 Outside: H14" X W14" X D12-1/2"  
 Inside: H13-1/2" X W13-1/2" X D7-1/4"  
 Weight: 101 lbs.

**IFS-1613**  
 Outside: H14" X W14" X D16-1/8"  
 Inside: H13-1/2" X W13-1/2" X D11-1/3"  
 Weight: 137 lbs.



**IFS-812**  
 Outside: H8" X W8" X D15"  
 Weight: 45 lbs. • 1/2" Door

**IFS-812S (Slotted Door)**  
 Outside: H8" X W8" X D15"  
 Weight: 45 lbs. • 1/2" Door

**IFS-812C (1" Door)**  
 Outside: H8" X W8" X D15"  
 Weight: 45 lbs. • 1/2" Door

# WALL SAFES

SFW-52EN

## FEATURES:

- Electronic lock
- Reversible door
- Concealed hinges
- Mounts flush to the wall
- Door plate thickness 5 mm
- Wall thickness 2 mm
- Easy installation instructions provided
- Manual key override
- Low battery warning
- Outside: 20-1/2" X 13-3/4" X 3-3/4"
- Weight Approx: 37.5 lbs.



# WALL SAFES

- The double reinforced heavy 16 gauge steel door
- Comes in combination or key lock
- Flush-to-the wall mounting and easy concealment.
- The 500 cubic inches of storage space provides ample room for cash, stocks, jewelry and other valuables.



	INTERIOR			OPENING		FACE PLATE		WEIGHT
	W	D	H	W	H	W	D	
3100C	14-3/8"	3-3/4"	9"	12-1/4"	6"	16-3/8"	11"	9 LBS.
3105K	14-3/8"	3-3/4"	9"	12-1/4"	6"	16-3/8"	11"	9 LBS.

## WALL SAFES

In-wall safe designed to be concealed behind a picture or mirror

**FEATURES:**

- Hidden hinges and a removable shelf
- Depth can be adjusted according to customer preference
- Hefty 19 (3/4" solid chrome plated locking bolts)
- High security dimple key which retracts the bolts
- 1/4" thick solid steel door & 1/16" thick solid steel body

EW (ELECTRONIC & KEY)

SW (KEY ONLY)



EW-02M

**OTHER MODELS AVAILABLE BY SPECIAL REQUEST**

	H	OUTSIDE		D	WEIGHT
		W			
EW-01M/SW-01M	13-7/8"	17"		4"	30 LBS.
EW-02M/SW-02M	19-1/4"	14-1/4"		4"	42 LBS.
EW-03M/SW-03M	11-1/2"	14-1/4"		4"	41 LBS.

## WALL SAFES

**FEATURES:**

- Solid steel plate door and body
- 1/4" door & 1/8" body
- Hidden hinges & removable shelf



WS1414E



WS2014E

	OUTSIDE			BODY			WEIGHT
	H	W	D	H	W	D	
WS1414C/WS1414E/WS1414K	16"	16"	4"	14"	14"	3-3/4"	35.25 LBS.
WS2014C/WS2014E/WS2014K	22"	16"	4"	20"	14"	3-3/4"	46.25 LBS.

# KEY SAFES

## FEATURES:

- With electronic lock
- 48 key hangers
- Concealed hinges
- May be bolted to floor or wall
- EN(S) - Comes with key deposit slot
- Electronic lock to program with 3-8 numbers
- Manual override key
- Powder coated in & out
- Pre-drilled holes with mounting bolts



SFK-48EB



SFK-48EN(S)

	H	OUTSIDE		WEIGHT
		W	D	
SFK-48EB/SFK-48EN(S)	14-1/4"	11-3/4"	3-7/8"	18 LBS.
SFK-48EN(S) SLOT: 2"H X 1-1/4"W				

# KEY SAFES

## FEATURES:

- Comes with keypad lock and key override
- Holds keys on hooks



K-37



	OUTSIDE			BODY	WEIGHT
	H	W	D	MM	
K-37 (HOLDS 210)	14-1/2"	9"	21"	2.3 - 4	62 LBS.
K-62 (HOLDS 550)	33"	24-1/2"	17"	2.3 - 4	143 LBS.



# KEY SAFES

## DIGITAL KEYSAFE

Designer key box with electronic time stamp that records last nine access events. Easy-to-use, one-hand operation ensures quick access. Low profile, subtle design compliments door frame with a variety of natural colors. Change code anytime for added security. Know what time your children and others enter your home.

### FEATURES:

- Battery-operated digital clock/calendar for tracking last nine entry times/dates
- Solid, weather resistant zinc alloy construction
- Available in white, beige, gray
- Includes all mounting hardware and battery
- Holds one conventional door key
- Patented pushbutton technology with over 1,000 possible combinations



1847



## KEYSAFE

Designer key box with easy one-hand operation for quick access. Available in assorted natural colors to compliment the trim of your home and mounts easily. Combination can be easily changed as often as desired.

### FEATURES:

- Solid, weather resistant zinc alloy construction
- Available in white, beige, gray
- Includes all mounting hardware
- Holds one conventional door key
- Patented pushbutton technology with over 1,000 possible combinations



1879



# KEY SAFES

## KEYSAFE ORIGINAL (PERMANENT)

Permanent KeySafe holds up to five keys and attaches securely to any wall or flat surface with mounting hardware included. The Strong Box design has a solid track record for unmatched quality and security.

### FEATURES:

- Double-walled zinc alloy construction
- Holds up to five conventional keys
- Available in white, clay, titanium, black
- Includes all mounting hardware
- Available in easy pushbutton, spin dial and mortise combinations



S6P



## KEYSAFE ORIGINAL (PORTABLE)

Hangs easily on any doorknob, fence, railing or pipe. Just open the key box, lift the shackle and hang. No tools are necessary. Stores up to 3 conventional keys. Case-harden shackle and zinc-alloy box have a protective cover so it won't scratch. Comes in assorted colors.

### FEATURES:

- Tough, single wall construction
- Holds up to three conventional keys
- Available in clay, black, and titanium
- Includes full rubber jacket around key box and rubber sleeve on shackle
- Available in easy pushbutton and dial combinations



C3P



# KEY SAFES

## KEYSAFE ORIGINAL (SLIMLINE)

Durable and stylish designed key box available in assorted colors. Its easy pushbutton opening is great for kids. Stores up to 2 conventional keys. Attaches securely to any wall or flat surface

### FEATURES:

- Double-walled, weather-resistant zinc alloy construction
- Holds up to two conventional keys
- Available in white, clay, titanium
- Includes all mounting hardware
- Patented pushbutton technology with over 1,000 possible combinations



## KEYSAFE AUTO

The KeySafe Auto is the perfect key storage unit for motor homes, trailers, and car or truck owners wanting to secure a spare car key, boat key, bike or ski rack key. The KeySafe Auto is designed to hold up to two conventional keys and permanently attach to the frame, wheel weld, tow hitch, or trailer tongue. The included four self-tapping screws and mounting plate offer a variety of installation options. The window mounted version of the KeySafe Auto is ideal for joggers and walkers who don't want to carry their car keys and need a temporary place to secure them. The unit slips easily over a window and is secured by rolling the window up. No tools needed. Equipped with stainless steel hanger and encased in rubber to protect window surfaces.

### FEATURES:

- Includes durable silicon-rubber cover that resists road grime, snow, ice, salt, and water
- Includes four self-tapping screws and mounting plate
- Patented pushbutton technology with over 1,000 possible combinations



# KEY SAFES & ORGANIZERS

## KEYSAFE PRO

The KeySafe Pro offers both a highly durable and generous size for storing access cards, multiple keys and keys with larger handles. Patented pushbutton technology allows quick and convenient access. Perfect for shops and maintenance crews needing to store multiple keys, as in lockout/tagout applications.

### FEATURES:

- Double-walled, weather-resistant zinc alloy construction
- Includes an all-weather rubber cover
- Available in black and clay
- Patented pushbutton technology with over 1,000 possible combinations



1267

## KEYSAFE ACCESSORIES

Lids are protective covers for the KeySafe Original Series



SUPRA COVER



PORTABLE COVER

## KEY STRIP

Keep your keys in one central location in this innovative key strip. Key is inserted into up to nine slots, which holds an entire ring of keys. Mounts to wall securely with screws and anchors.



1887



## KEY ORGANIZER

Keep your keys in one central location in this Designer key organizer that mounts easily. Organize everyday items such as key rings, cell phones and wallets in cups on the outside. Concealed, inner cabinet stores backup keys with identification labels.



1888



# KEY SAFES & ORGANIZERS

## KEY CABINET

Key cabinet that stores all of your keys in one place on peg hooks or removable key tags with labels for easy identification. Modern design that mounts easily with spring-loaded door.



1889



## LOCKING KEY CABINET

Electronic locking key cabinet with resettable combination and lockout feature. Audio signals let you know if code was entered correctly. Hidden chamber for long-term storage of keys. Adjustable peg hooks for large sized key rings. Low battery indicator (batteries not included). Ideal for small offices or wherever key control is a problem.



1890



## KEY SAFES & ORGANIZERS

### KEY CABINET PRO

These heavy-duty steel key cabinets are a great value. Includes numbered key tags with key rings and lock location chart for easy reference. Available with pushbutton (TouchPoint) or keyed lock (Standard). TouchPoint pushbutton lock combines convenience and security. The entry code can be changed as often as you like to over a thousand different combinations. Standard key cabinet has a keyed cam lock and two keys.

#### FEATURES:

- 16 gauge steel construction
- More depth for larger key rings
- Keys hang directly on hooks
- Available in 30, 60 and 120 key sizes
- Instant access (TouchPoint)
- Clutch mechanism protects from forced entry (TouchPoint)
- Never re-key locks again (TouchPoint)

### TOUCHPOINT

TouchPoint Pushbutton Lock combines convenience and security. Entry code can be changed as often as you like to over a thousand different combinations.

#### FEATURES:

- Instant access
- Clutch mechanism protects from forced entry
- Never re-key locks again



1795  
30-KEY TOUCHPOINT



1796  
60-KEY TOUCHPOINT

# KEY SAFES & ORGANIZERS

## STOR-A-KEY

An affordable, simple key case with powerful magnet that attaches to almost any clean surface. Stor-A-Key can be used for emergency access to vehicles or in your home. Weather resistant plastic will not rust. Foam insert and strap keeps key in place.



1843

## LOCKING STOR-A-KEY

Popular with consumers who desire an extra level of deterrence when hiding their spare keys. This unique, affordable, locking storage case has a resettable combination and powerful magnet. Spare key storage for auto, home, boat, office files, etc. Easy key retrieval and foam insert to keep key from rattling around. Equipped with anchor point for strap or cable tie.

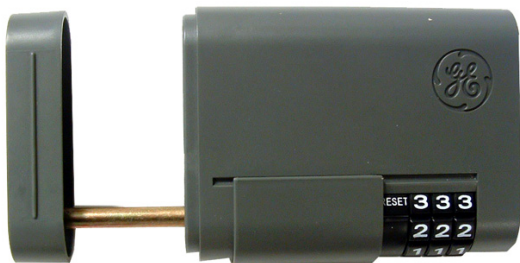

1844



## PORTABLE STOR-A-KEY

Versatile and portable key case with resettable combination lock and adjustable cable. The 8" cable hooks almost anywhere: hose bib, chain link fence, pipes, backpack/bag, shed, car/bike rack and more. Foam insert can be removed to hold more keys, cash and more. Lots of uses: for home, sports/recreation and kids.



1948



# KEY SAFES & ORGANIZERS

TOUCHPOINT LOCK, TITANIUM (GRAY)

TouchPoint lock is designed to replace a standard cam lock in a variety of storage cabinets or enclosures. It consists of a solid die cast body with a ten-digit changeable combination and a clutch mechanism to turn the cam. The TouchPoint lock can be mounted on top of the door surface or flush mounted into the door.



1773  
CLAY WITH BRACKET,  
FITS 3/4" DOUBLE D



1774  
TITANIUM WITH FACE PLATE  
FITS 1-1/2" DOUBLE D



TOUCHPOINT CABINET



TOUCHPOINT FILE CABINET



TOUCHPOINT MAILBOX



# KEY CABINETS

## FEATURES

- Combination dial lock
- Durable enamel finish

	OUTSIDE			WEIGHT
	H	W	D	
DKC-20 (20 HOOKS)	8"	6.3"	3.2"	3 LBS.
DKC-46 (46 HOOKS)	11.8"	9.5"	3.2"	5 LBS.
DKC-94 (94 HOOKS)	11.8"	9.5"	3.2"	7 LBS.



DKC-20

# KEY CABINETS

## FEATURES:

- Numbered hooks to coordinate with identification label inside
- Made of quality pressed steel + epoxy powder

	OUTSIDE			WEIGHT
	H	W	D	
KC-20 (20 HOOKS)	8"	7"	3"	2 LBS.
KC-45 (45 HOOKS)	12"	10"	3"	4 LBS.
KC-48 (48 HOOKS)	10"	7"	3"	4 LBS.
KC-93 (93 HOOKS)	12"	10"	3"	5.5 LBS.
KC-100 (100 HOOKS)	22"	15-1/2"	3-1/2"	6 LBS.
KC-320 (320 HOOKS)	21-5/8"	14-7/8"	5-1/2"	11 LBS.



KC-93

# KEY CABINETS

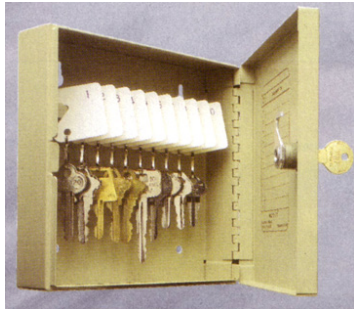

201-9010



201-9030



201-9110

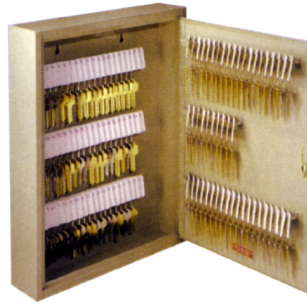

201-2028



201-KCH20PL

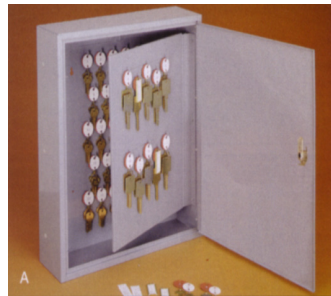

201-6194



201-8030

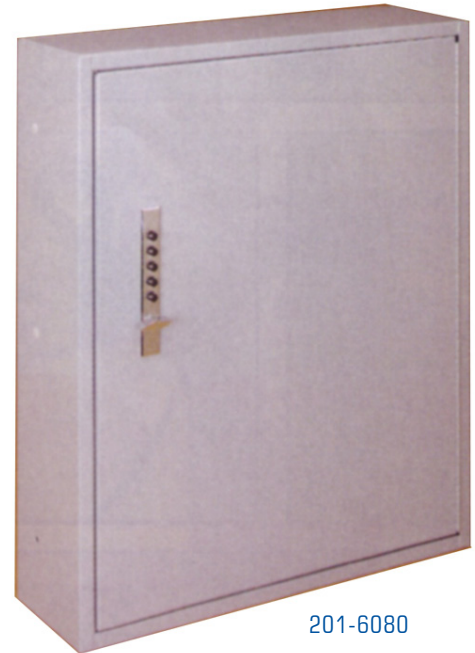

201-6080

	OUTSIDE				
	H	W	D	WEIGHT	DESCRIPTION
201-9010	6-3/4"	6-7/8"	2"	3 LBS.	10 KEY - SINGLE TAG
201-9030	12-1/8"	8"	2-5/8"	4 LBS.	30 KEY - SINGLE TAG
201-9110	17-1/8"	14"	3-1/8"	11 LBS.	110 KEY - SINGLE TAG
201-2028	11-1/2"	7-3/4"	3-1/4"	4 LBS.	28 KEY - HOOK STYLE
201-KCH20PL	8-1/2"	1-7/8"	10-1/8"		20 KEY - RING CABINET
201-KCH40PL	8-1/2"	1-7/8"	10-1/8"		40 KEY - RING CABINET
201-6194	31-1/8"	16-1/2"	5"	55 LBS.	144 KEY - BIG BOW KEY CABINET
201-6080	20-1/8"	16-1/2"	5"	19 LBS.	80 KEY - KEY CABINET WITH SIMPLEX LOCK
201-6160	20-1/8"	16-1/2"	5"	25 LBS.	158 KEY - KEY CABINET WITH SIMPLEX LOCK
201-8030	12-1/8"	8"	2-1/2"	6 LBS.	30 KEY - TWO TAG KEY CABINET
201-8180	20-1/2"	16-1/2"	5"	26 LBS.	180 KEY - TWO TAG KEY CABINET
201-8300	31-1/8"	16-1/2"	5"	42 LBS.	300 KEY - TWO TAG KEY CABINET

# KEY CABINETS, RACKS & CASES

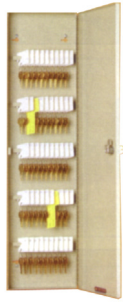

201-4250

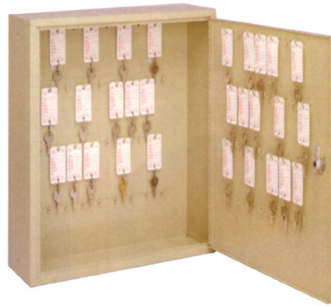

201-0006

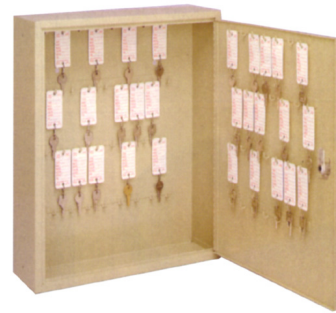

201-0108

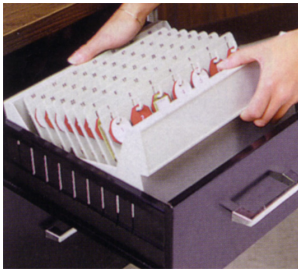

201-7056

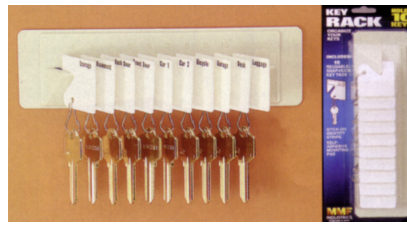

201-4010

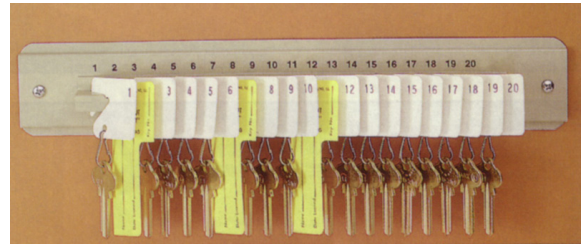

201-3020

## 201-4250 VERTICAL 50 KEY CABINET

28-3/4"H x 7-1/4"W x 1-5/8"D

## 201-0006 60 MOTOR VEHICLE KEY CABINET

20-1/8"H x 16-1/2"W x 5"D

## 201-0108 108 MOTOR VEHICLE KEY CABINET

31-1/8"H x 16-1/2"W x 5"D

## 201-7056 DUPLI-KEY IN-DRAWER KEY CONTROL

4-3/4"H x 12"W x 9-7/8"D • weight: 7 lbs.

## 201-4010 10-KEY RACK

2-1/4"H x 8"W • weight: 0.5 lbs.

## 201-3020 20-KEY RACK

2-1/4"H x 13-3/4"W • weight: 0.8 lbs.

## 201-5024 24 KEY PORTABLE ZIPPERED KEY CASE

7"H x 8-3/8"W x 1-1/4"D • weight: 1 lb.

## 201-5048 48 KEY PORTABLE ZIPPERED KEY CASE

8-7/8"H x 11-7/8"W x 1-3/8"D • weight: 2 lbs.

## 201-5016 16 KEY CASSETTE

8"H x 5"W x 1-1/8"D • weight: 0.3 lbs.



201-5024



201-5016

# CASH BOXES & DRAWERS



CASH BOXES & DRAWERS

# CASH BOXES, DRAWERS & MISC.

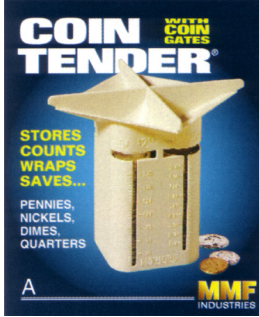

224-0006



225-1060



221-6120



221-6180

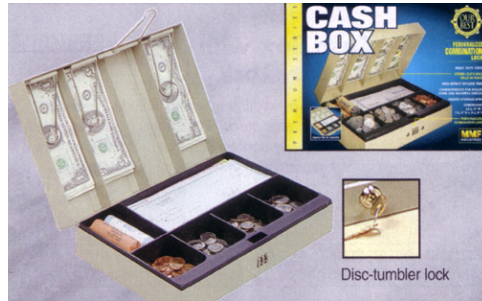

221-6188



221-1085



221-6140



221-6151

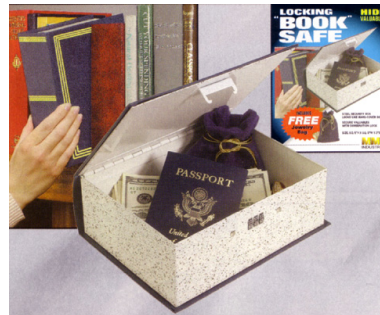

221-2032



240-0530-12



233-1108

221-6120  
CASH BOX WITH LOCKING LATCH  
4"H x 11"W x 7-3/4"D • weight: 7 lbs.

221-6180  
CASH BOX WITH SECURITY LOCK  
11-1/4"W x 7-1/2"L x 2"D

221-6188  
CASH BOX WITH LOCK & HANDLE  
11-1/4"W x 7-1/2"L x 3-1/8"D • weight: 4.5 lbs.

221-1085  
LOCK-DOWN SECURITY BOX  
5"H x 11-1/8"W x 7-1/2"D • weight: 7 lbs.

221-6140  
FIRE-RETARDANT SECURITY BOX  
4"H x 12-3/4"W x 8-1/4"D • weight: 6 lbs.

221-6151  
JUMBO STEEL SECURITY CHEST  
4"H x 12-2/3"W x 10-19/20"D • weight: 8 lbs.

221-2032  
LOCKING "BOOK" SAFE  
8-3/8"H x 6-1/2"W x 3"D

233-1108  
7-PIN SECURITY BAG IN RETAIL PACKAGING

240-0530-12  
5" YELLOW NUMBERED  
ALL-PURPOSE PLASTIC SEALS

224-0006  
COIN TENDER

225-1060  
"TOUGH BUTTON" CASH DRAWER